

1. Foreword

Date of last update: 20.04.2023

- Read this document carefully before assembling the product.
- Observe the safety instructions to avoid injuries and product damage.
- Contact the manufacturer if you have any questions about the product (e.g. commissioning, use, maintenance, unexpected operation or incidents). You will find the contact details at the end of this manual.
- Keep this document in a safe place.

The custom-made socket may be fitted only by an authorised specialist. The assembly instructions for the Explorer™ socket explain in detail how to make the socket usable. If necessary, the specialist can be instructed by macu4 employees or the official partners of macu4 within the scope of a training course on how the assembly should be carried out.

2. Socket structure

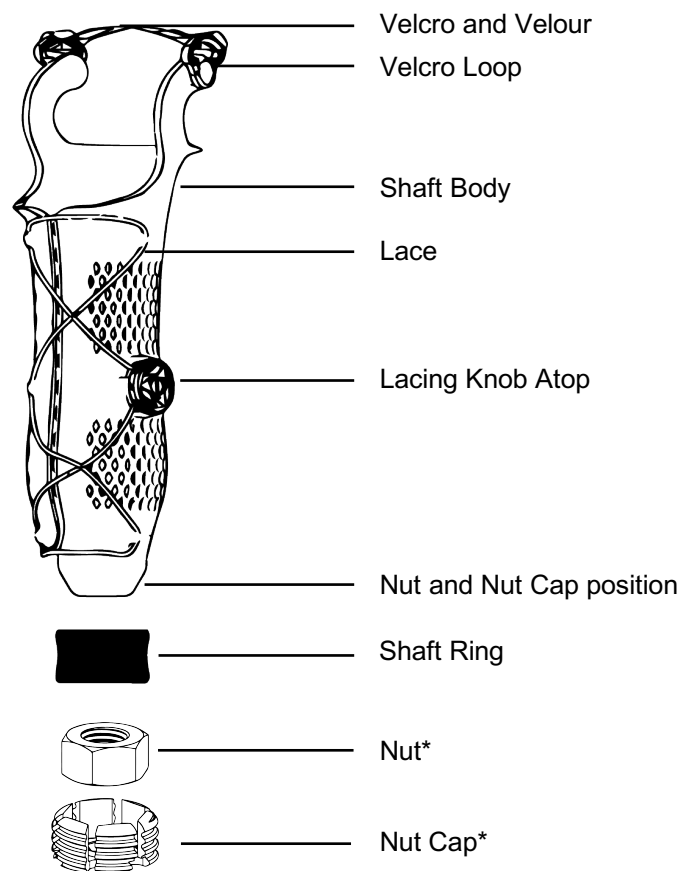

* The scale is not respected compared to the other elements.

3. Socket

The socket is a component of the socket system. It is completed in six steps.

Materials needed:

- Socket body, quantity: 1 piece
- Nut Cap, quantity: 1 piece
- Nut M12x1.5 or 1/2"-20, quantity: 1 piece
- Cushion disc, quantity: 1-2 pieces
- Self-adhesive velcro, quantity: ~20cm
- Velcro loops (loops for Velcro / Velcro tape), quantity: 2 pieces
- macu4 Velour Tape, quantity: 1 strip, ~1.3x15cm
- macu4 Double Sided Velcro, Quantity: 1 piece
- Atop, A-B41, quantity: 1 piece
- Dyneema cord (1mm), quantity: ~60cm
- Cushioning fabric, quantity: ~30x20 cm

Resources needed:

- Screw, M12x1.5x30mm (or 1/2"-20 3/4"), quantity: 1 piece
- Plastic washer, quantity: 1 piece
- Scissors large, quantity: 1 piece
- Textile pencil with white lead / chalk, quantity: 1 piece
- Scissors small/fine, quantity: 1 piece
- Hex key 8mm (Allen wrench), quantity: 1 piece
- Cutter / carpet knife, quantity: 1 piece
- Flat pliers (e.g. combination pliers), quantity: 1 piece

Step 1

Set the nut in place. The Hex Key is required here.

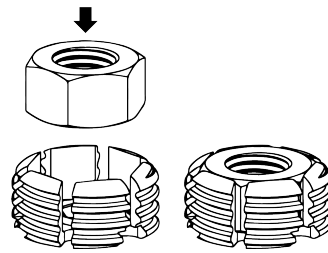
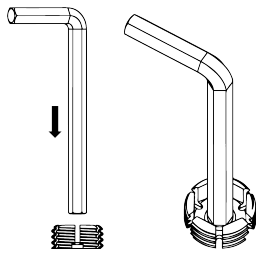

Place the Nut Cap onto a table as illustrated and insert in the Hex Key in it. A little pressure might be needed.

Remove the Hex Key and place the nut in the Nut Cap.

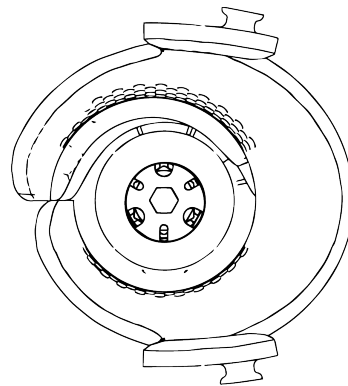
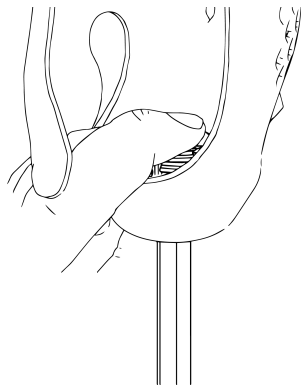

With your finger, press the Nut Cap with the nut inside against the threaded hole in the socket from the inside while you insert the Hex Key into the hex hole of the nut cap through the round distal hole of the socket. If the socket is long, a tool can be used instead (like the handle of a hammer). The side of the Nut Cap, where the nut is visible, faces down in the illustration above.

Maintain constant pressure from the inside until the thread engages. Continue to screw clockwise until the nut cap and the inside of the Socket form a flat surface.

Step 2

Use the padding disc to pad the distal end of the socket. After gluing in the padding disc, you can optionally insert further padding discs.

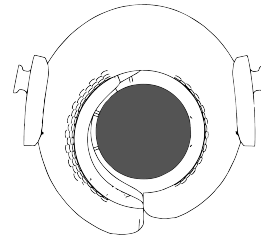
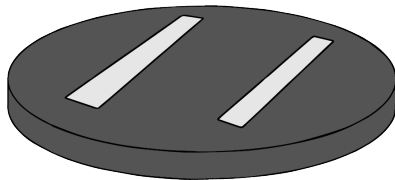

Place two pieces of self-adhesive Velcro on the cushioning disc. The center of the disc, where the hexagonal hole of the Nut Cap is, should remain free. Now remove the protective foil.

Position the padding washer inside the socket (shown here in black). Make sure that the disc remains in the desired position. Check one more time from the other side that no adhesive is visible through the hexagonal hole.

Step 3

Use the spacer fabric for padding the rounded edges in the proximal area of the socket.

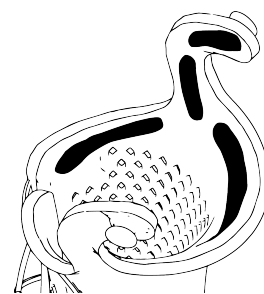
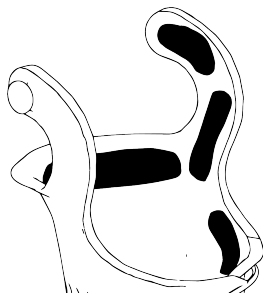

Cut out two approx. 1x1cm pieces of the self-adhesive Velcro material. Round off the edges. Stick one of each of these two pieces on the inside of the condylar braces.

Cut out five approx. 1x3cm pieces of the self-adhesive Velcro material. Round off the edges. Stick along the proximal end of the socket. Spread the strips evenly. Make sure that the strips are approx. 3-5mm away from the outer edge.

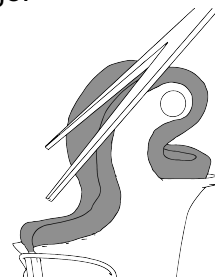
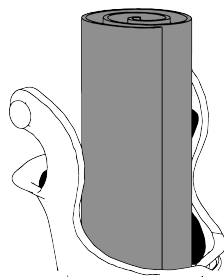

Use the cutting template for the cushioning material and cut it accordingly. Take the pre-cut piece and insert it about 2-3cm into the socket. Then unfold it gradually so that it is fixed along the proximal edges and the condylar brace.

Trim those areas that do not yet correspond well enough to the shape of the socket edge including the condylar clasps. Make sure that the material overlaps the socket edge by 5-10mm.

Step 4

Mount the Velcro loops together with the Velcro tape.

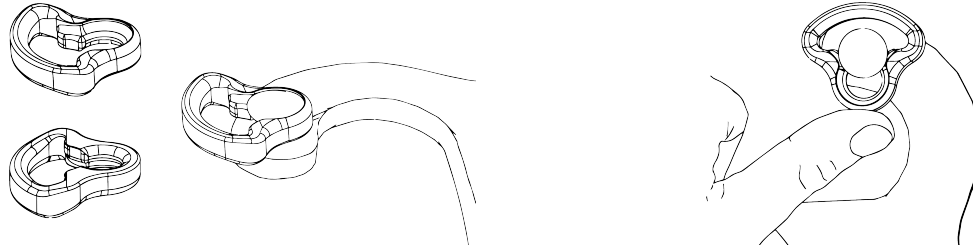

Take the two Velcro loops. These are attached to the outer end of the condylar braces.

Press one Velcro Loop at a time onto the designated spot on the condylar brace. Occasionally you may need to press a Velcro loop harder to slide it over the corresponding nub.

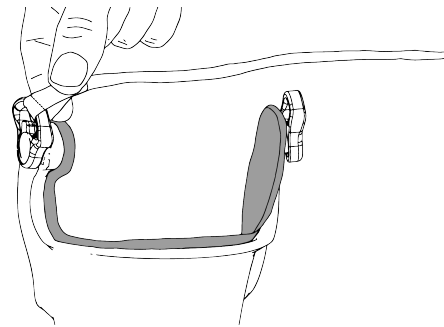

Take the macu4 Velour Tape and the macu4 Double Sided Velcro.

Pass the end of the macu4 Velour Tape with the sewed Velcro through the Velcro loop of the medial condyle clip towards the inside of the socket. Confirm that the Velcro is correctly in place.

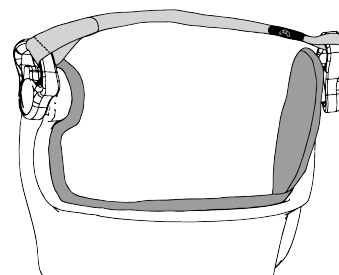
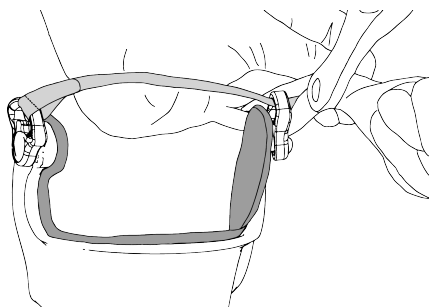

Pass the other end of the tape through the Velcro loop of the lateral condylar brace. Cut it off directly at the level of the Velcro loop.

Place the macu4 Double Sided Velcro at the extremity of the macu4 Velour Tape and close the system without applying pressure. This allows the user to tighten the macu4 Velour Tape fastener as needed.

Step 5

Place the laces from the lacing system.

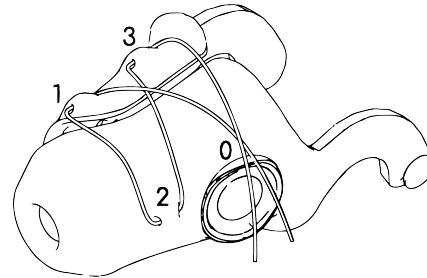
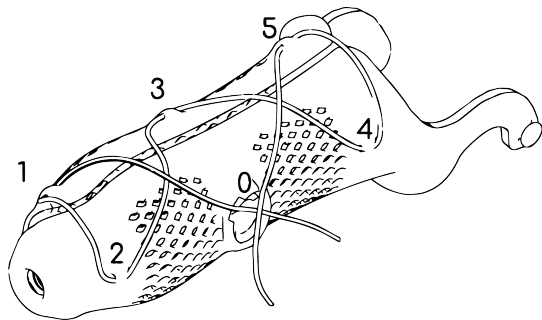

Example for a larger socket:

Insert the string into guide channel #1. Guide the string step by step as shown in the diagram to the last guide channel #5. A larger socket has up to 5 guide channels. Note that the ends of the string meet at point 0.

Example for a smaller socket:

Insert the string into guide channel #1. Guide the string step by step to the last guide channel #3 as shown in the diagram. A smaller socket has 1 to 3 guide channels. Note that the ends of the string meet at point 0.

Step 6

Connect the laces to the 'atop'.

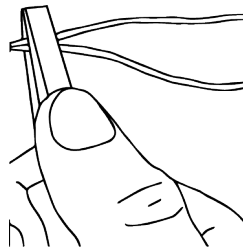

Cut the end of the cord that protrudes from the guide channel #1 or #5 at approx. 30cm cord length overhang with a cutter. The cut surface must not be frayed when cutting through. A swift cut with moderate pressure works better with Dyneema than light sawing movements.

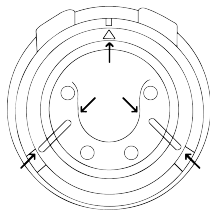

Align the cable channels of the 'atop' button so that the two cord ends can be inserted. To make this easier, there are lines and an arrow on the bottom of the 'atop' button.

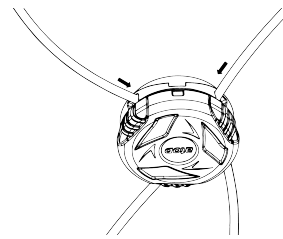

Insert one end of each cord over the outside into the respective cable duct. The cord end should come out on the inside or underside of the 'atop'. Be sure to insert the cords into the correct holes by holding the 'atop' against its base in the socket, checking which cord end goes to which hole.

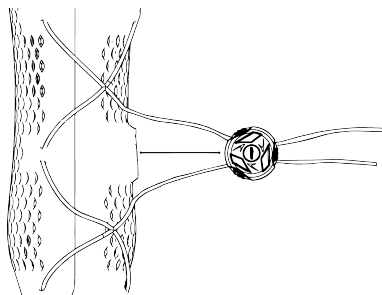

Lay the string from guide channels #1 and #5 (in the case of a socket with 5 guide channels) to the 'atop' base and stretch it about 7cm further each to find the place where the knot is to be made.

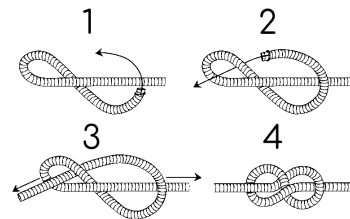

Make a figure-eight knot in each of the ends of the cord. Tighten this very tightly, e.g. with a pair of combination pliers. Choosing the right knot is important because Dyneema is very slippery and other knots could come loose.

Step 7

Cut the respective snood end behind the figure-eight knot and position the 'atop'.

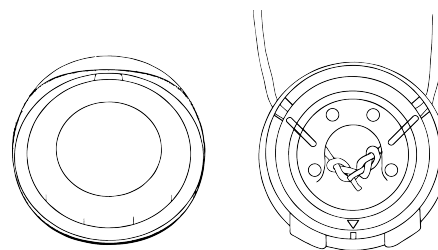
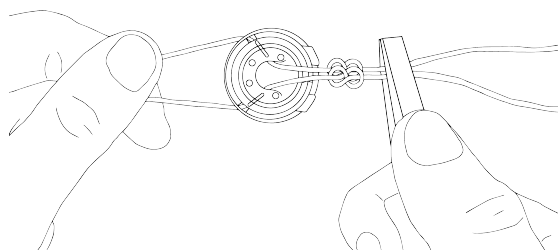

Use combination pliers to grab the respective loose end of the cord. Use your other hand to grab the long end of the cord sticking out of the 'atop'. Now tighten the two knots individually or simultaneously. Cut off the excess end of the cord.

The base has two recesses that branch away from the cords and one recess that points towards the cords. The 'atop' itself has one protruding edge on the side through which you have inserted the strings and two protruding edges on the opposite side.

Important: Make sure that the cut end is not too short to avoid loosening the knot.

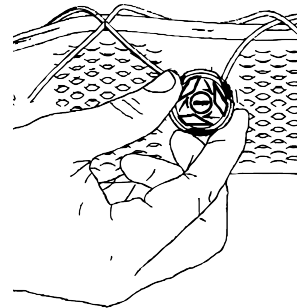
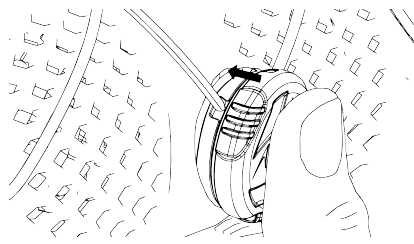

Anchor the 'atop' in the atop base. First, push the two protruding edges of the 'atop' rim into the recesses provided. Then press the entire 'atop' into the base.

Check that the lacing system is working properly by turning the knob to the right to tighten the lacing and then by turning the knob to the left and pulling gently on the laces to loosen them.

4. Legal notice

Limitation or exclusion of liability

macu4 AG, hereinafter referred to as Macu, expressly claims that appropriate tests have been carried out only for the component combinations and assembly steps specified in these assembly instructions as part of product development and validation and verification. Macu shall not be liable for damage caused by component combinations and applications that have not been approved by Macu for the delivered product, in this case, a semi-finished product. This also includes subsequent modification of the semi-finished product, such as deformation or trimming of the material.

Contact

macu4 AG
Rämistrasse 18
8001 Zurich
Switzerland
CHE-301.889.074

5. Returns

If you think there is a problem with the delivered product, in this case, a semi-finished product, contact support@macu4.com.

Please state the article and lot number of the semi-finished product when requesting returns. You will find these printed on the inside of the semi-finished product.

6. Document history

Version	Date	Description
1.0	28.12.2021	Creation
2.0	13.07.2022	Update
3.0	20.04.2022	Update of Step 1 and all images.