

1. Foreword

Valid from: 14.01.2025

- Read this document carefully before using the product.
- Contact the manufacturer if you have any questions about the product (e.g., commissioning, use, maintenance, unexpected operation or incidents). You will find the contact details on the back.
- Keep this document in a safe place.

These instructions provide important information on using, adjusting, and handling the Lynk Interface.



Please note that in addition to the present instruction, you should consider the Instructions for the Use of the Lynk System. Additionally, there are several explanation videos available. See <https://macu4.com/en/application-lynk>.

The Lynk Interface is a semi-finished part. It may be used only by an authorised specialist. It is possible to combine the Lynk Interface with a custom-made cuff/orthosis using two different approaches. If necessary, the specialist can be instructed by macu4 employees or the official partners of macu4 within the scope of a training course on how the recommended steps should be carried out.

Important considerations

- Several ways are possible to integrate the Lynk Interface into a custom-made cuff, such as thermoforming, lamination, or prepreg.
- The present instructions shows the Interface used for a lamination technique.
- The Lynk Interface may deform if too high temperature or too high pressure is applied.
- No material shall remain inside the Lynk Interface in the finished orthosis.
- The Lynk Interface shall not be weakened, i.e. be careful when using abrasive processes.

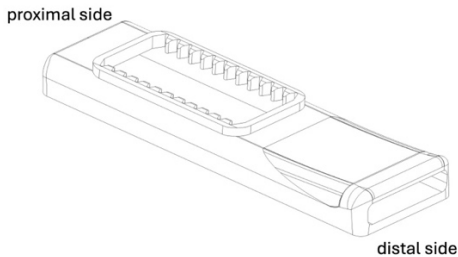
2. Interface for Lamination - Design and structure

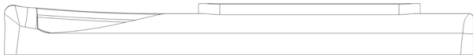
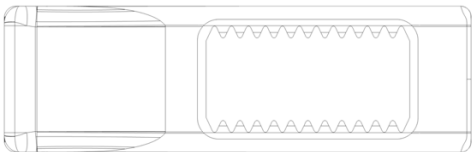
General	
Drawing (overview)	 <p>proximal side</p> <p>distal side</p>
Drawing (front)	
Drawing (side)	
Drawing (top)	

Dimensions (bottom)	
Dimension (side)	
Weight	Approx. 30 g
Material	Module body: PA2200, coloured with DM standard colour (DyeMansion)
Allowed products to be inserted into the Interface	Lynk Modules, which intended to be used together with a Lynk Cuff

3. Approach – Direct integration

3.1. Required material

Third-party material

- Acrylic resin
- Fabric hose
- Unidirectional carbon fibre
- Silicone paste | Shore 80 (e.g. Sheraduet)
- Stick wax

Lynk Interface Dummies

The dummies serve to protect the integrity of the Lynk Interface. There are 3 types of dummies which shall be used.

<p>Part 1.1 – Dummy A Used to be inserted from the distal end</p>	<p>Part 1.2 – Dummy B Used to be inserted from the distal end into the Dummy A</p>	<p>Part 2 –Dummy C Used to be inserted from the top</p>

Lynk Interface assembled with Dummies

Overview

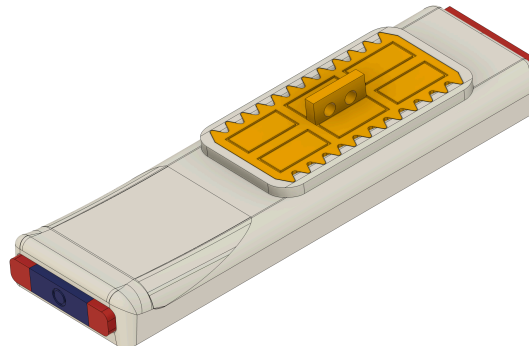

3.2. Recommended steps

The present steps below illustrate an example of lamination with acrylic resin and unidirectional carbon fibres. The photos are used exemplary and the sample of the Interface shown here is the “Interface for Screwing” and not the “Interface for Lamination”.

Preparation of the model

- Create a plaster cast of the limb. The limb shall stand in the desired position.
- Place the first layer of foil around it.
- Create a base layer. Here, a white fabric hose is used. It serves to prevent direct skin contact with the carbon fibres



First application of carbon fibres

- Place the first layer of unidirectional carbon fibre.
- Define the desired orientation of the Lynk Interface. An inserted plate or a Lynk module may help imagine the final result.



- Use some material such as plaster or silicone paste (Sheraduet) to create a small flat area.
- Consider that the modules have enough space to be inserted and removed from the interface without colliding with the rest of the orthosis.



Warning: Pay attention to the direction of the orientation of the Interface. The proximal side needs to face the proximal side of the forearm model.

macu4™ | Assembly Instructions

Lynk System – Interface for Lamination



Usage of the Dummies

- Insert the dummies in the Lynk Interface. Follow the indicated order of inserting the dummies. Seal the openings with stick wax.

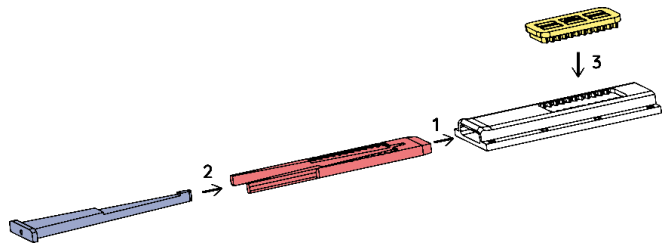

Second application of carbon fibres

- Apply stepwise the required layers of carbon fibres.

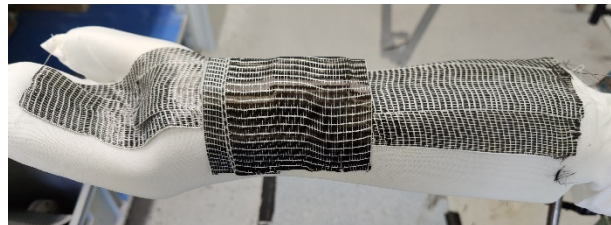
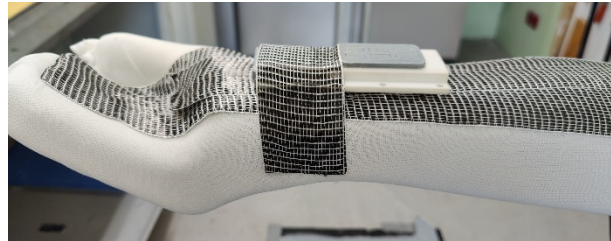

Usage of resin

- Pour resin between the two foils. Here, blue acrylic resin is used.



Hardening of material

- Let it harden the material. For acrylic resin about one hour shall be considered. Please refer to the instructions of the material you are using.

Removal of dummies

- Grind free the distal opening in which Dummy A and B have been inserted and the opening for Dummy C.
- First, remove Dummy C by pulling it out.



macu4™ | Assembly Instructions

Lynk System – Interface for Lamination



- Remove the Dummy B. There is a small hole in the middle. Break the bottom of the hole and screw in the provided M3 screw and pull on it.

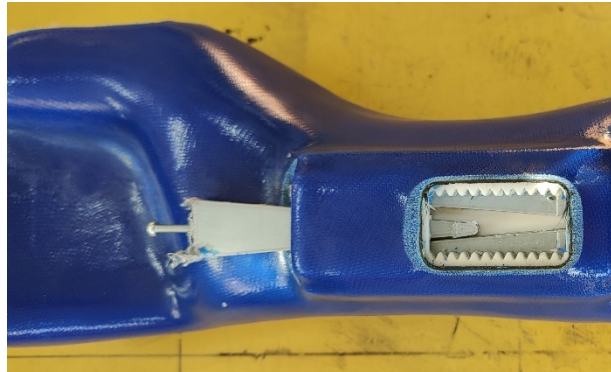

- Remove Dummy A. It has a V-shape and this allows you to press the V-edges slightly together. This will help you to remove Dummy A. A sharp or pointy object like a screw driver can be used.

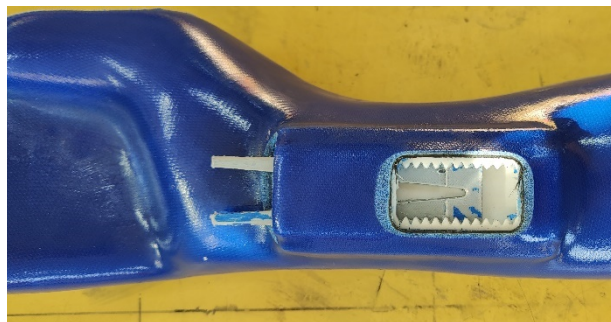

Final cleaning

- Clean the Lynk Interface from residual wax. Cleaning the Lynk Interface is crucial and required to assure compatibility with the Lynk Modules.

Testing

- Confirm the functionality by connecting a Lynk Module.
- If inserting or operating the module is too difficult, further cleaning of the channel of the Lynk Interface is required.

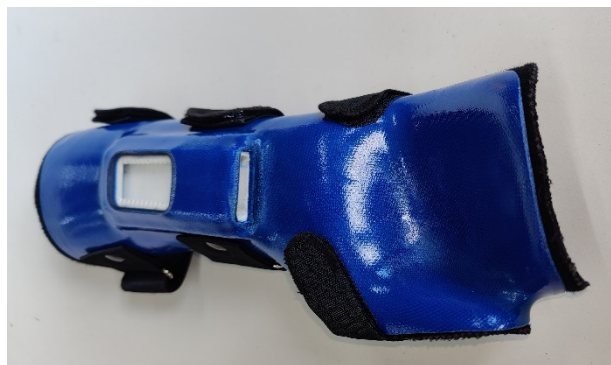

Completion

- Smoothen the grinding locations to prevent sharp edges.

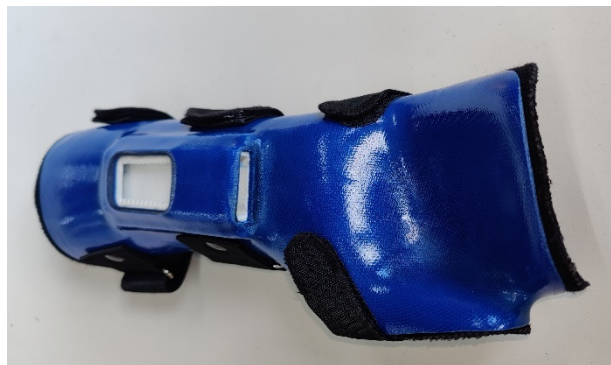

- Apply adapted cushioning and a closing mechanism.



4. Legal notice

Limitation or exclusion of liability

macu4 GmbH, hereinafter referred to as Macu, expressly claims that appropriate tests have been carried out only for the component combinations and assembly steps specified in these assembly instructions as part of product development and validation and verification. Macu shall not be liable for damage caused by component combinations and applications that have not been approved by Macu for the delivered product, in this case, a semi-finished product. This also includes subsequent modification of the semi-finished product, such as deformation or trimming of the material.

Contact

macu4 GmbH, Bücklestrasse 3, 78467 Konstanz, Germany

5. Returns

If you think there is a problem with the delivered product, in this case, a semi-finished product, contact support@macu4.com or your sales representative.

Please state the article and lot number of the semi-finished product when requesting returns. You will find these printed on the inside of the semi-finished product.

6. Document history

Version	Date	Description
1.0	14.01.2025	First version